

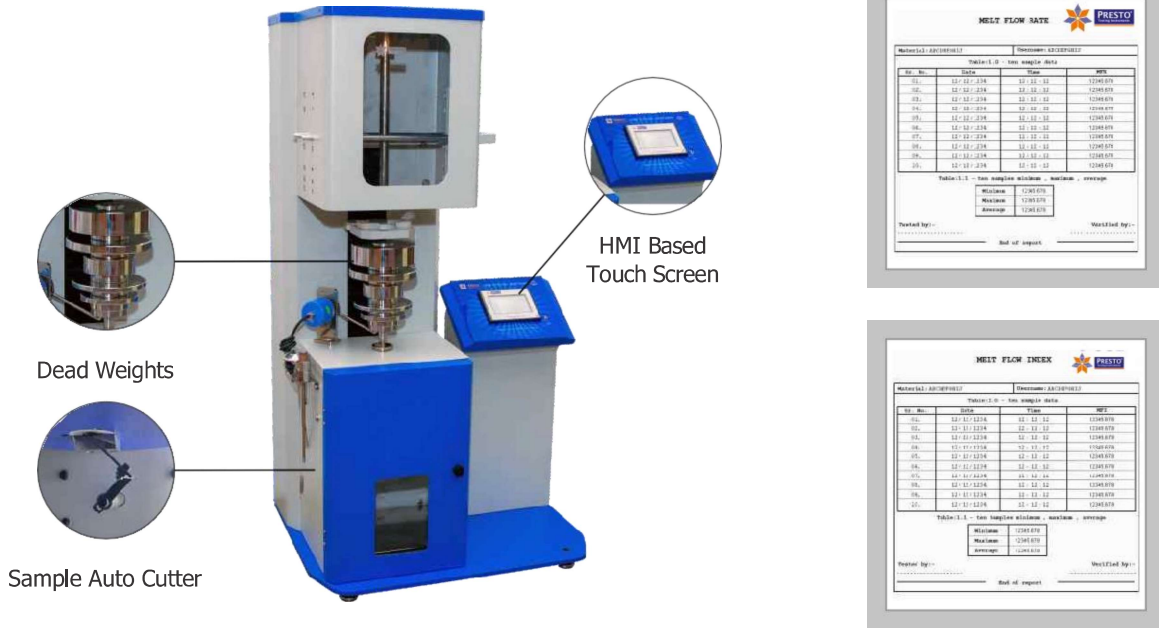

Melt Flow Index - MFR Model (Method - A & B)



Model No. MFI-MFR

Melt Flow Index / Rate Tester - The melt flow index (MFI) or melt flow rate (MFR) is a measure for the ease of flow of melted plastics. It is often used in the plastic industry for quality control of thermoplastics. The method is described in the standards ASTM D1238 and ISO 1133. **** Applicable only upto 20 MFI ****

- HMI based Touchscreen Model
- Inbuilt Calculator for calculating the MFI / MFR Valve
- Microprocessor based inbuilt PID controller
- Automatic sample cutting
- Temperature setting and Preset Timer functions incorporated in HMI for accuracy and repeatability
- Die Steel barrel for uniform and consistent heating of barrel/test cylinder.
- Temperature Vs Time Graph.
- Program profile for selecting test parameters and performing the test.
- Easy Data Management. User can create product identification, test temperature, time etc.
- USB option available for storing test data (Pen drive not a part of offer).
- Current test running status display
- Placement of dead weight is auto motorised.
- Data output in PDF and CSV file format.

Melt Flow Index MFR Model is defined as the rate of flow of extrudate of molten resins through a jet of a specific length and diameter under prescribed conditions of temperature, load and piston position inside a heated metallic barrel. Melt flow Index of thermoplastic material is expressed in terms of grams per 10 min of extrudate of molten resins that flow through the heated cylindrical barrel. Also the melt density (grams/cu.cm) is essential factor of calculating melt flow rate by this method. As this method can measure linear displacement of Piston.

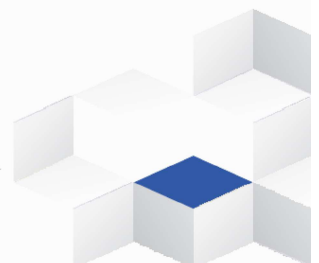
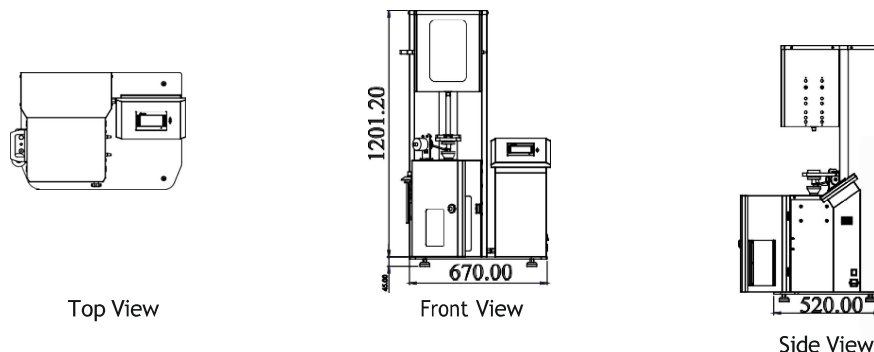



Presto Stantest Pvt. Ltd.

I-42, DLF Industrial Area Phase-1, Delhi Mathura Road, Faridabad 121003, Haryana, India
 P : 9210 903 903, +91 129 4272727, 93111 24302 E : info@prestogroup.com



- Faridabad • Sonipat • Kolkata • Mumbai • Pune • Ahmedabad
- Chennai • Bangalore • Hyderabad

www.prestogroup.com

Key Specifications:

Display	HMI Based touchscreen 4.3"
Temperature Range	Ambient to 400° C
Accuracy	± 1°C
Least Count/Resolution	0.1°C
Power	220V , Single phase, 50 Hz
Sample Cutting	Automatic Motorized
Temperature Control	Inbuilt PID Temperature Controller
Timer	Inbuilt in HMI Preset Timer upto 999 sec.
Inner Diameter of heating barrel(cylinder)	9.550mm ± 0.007mm
Inner Diameter of Die	2.095mm ± 0.005mm
Diameter of piston head	9.474mm ± 0.007
Material of Heating Barrel(Cylinder)	Die Steel
Sample Cutting Motor	Torque 7Kg/cm ² , 60RPM
Piston Travel	upto 25 mm least Count 0.02mm

Highlights:

No. of Dead Weights	7 (0.325kg, 1.2kg, 2.16kg, 3.8kg, 5kg, 10kg, 21.6kg)
Material	Mild Steel
Finish	Powder coated Havel Gray & Blue combination finish and bright chrome / zinc plating for corrosion resistant finish
Test Method	A & B

Optional Features:

- Melt Flow Index Deluxe / NEO 2.0 model also available.
- Digital Weighing balance available as an optional accessory.
- The Melt Flow Index in grams per 10min. of the test specimen can be calculated on the HMI screen with In-built calculator facility.
- Other specific deadweight also available on request

Thank you customers for choosing us as your partners in growth !



*All the above logos are the sole property of their respective owners and are used purely for depiction purposes only.

Our Other Products :



Melt Flow Index - NXG

Melt Flow Index - Dx

Melt Flow Index - Neo 2.0

Humidity Cabinet

Colour Matching Cabinet Spectrum 1

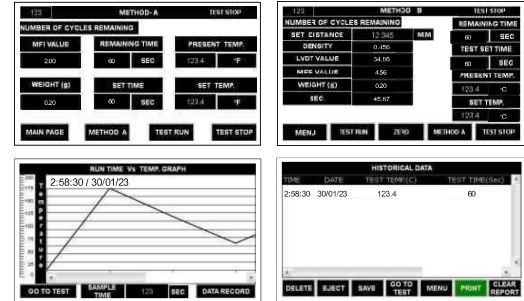

Features of the touch screen include :

- 8 function keys
- 4.3" (480 * 234) 16:9 TFT LCD 65536 colors
- Provides USB Host for USB flash drive
- Supports CF memory card
- USB 1.1 for high-speed screen data download
- 480 x 234 pixels IP 65 compliant
- 3M Flash Memory

Standard Accessories :-

- Orifice Inbuilt - 1
- Funnel - 1
- Mirror with stand - 1
- Piston - 1
- Deadweight - 7
- Orifice cleaner - 1
- Barrel cleaner - 1
- Material Charger - 1
- Plumb line - 1
- Spool - 1